



Mixing Console



MX Series USER MANUAL

一、功能特点

- 8路/12路/16路调音台。
- 话筒输入带48V幻象电源供电选择。
- 单声道输入配备高品质话筒放大器。
- 2路编组输出及2路辅助输出。
- 内置专业数码混响效果器。
- 每通道话筒有高、中、低3段参量均衡器。监听电平显示。
- 外置式低噪声电源设计。
- 备有录音输入输出功能。
- 具有USB录音和播放功能
- 输出方式：主声道双声道平衡、6.35插座。SUB双声道6.35插座。

二、技术参数

型号		MX 8-422U	MX 12-822U	MX 16-122U
麦克风输入	通道	4路	8路	12路
	幻象电源	48V		
	频率响应	20Hz~20KHz(+1dB,-3dB)		
	信噪比	71dB		
	THD+N	≤0.05%(1KHz, 0.775V)		
	最大输入电平	19dBm(1KHz, THD=0.5%)		
单声道输入	通道	4路	8路	12路
	频率响应	20Hz~20KHz(+1dB,-3dB)		
	THD+N	≤0.05%(1KHz, 0.775V)		
	最大输入电平	19dBm(1KHz, THD=0.5%)		
立体声输入	通道	2路		
	频率响应	20Hz~20KHz(+1dB,-3dB)		
	THD+N	≤0.05%(1KHz, 0.775V)		
	最大输入电平	19dBm(1KHz, THD=0.5%)		
输入增益	单声道	-55dB~0dB		
	立体声	-10dB、0dB		
剩余噪声	-75dB			
均衡	低频	80Hz, ±15dB		
	中频	2.5kHz, ±15dB		
	高频	12kHz, ±15dB		
电源供应	电源电压	AC220V-240V/50Hz-60Hz		
物理特性	尺寸 (长*宽*高)	400*400*45mm	443*400*45mm	560*400*90mm
	重量	4.41kg	5.57kg	7kg

三、面板介绍

1、麦克风平衡输入口，当使用非幻像供电的麦克风时，务必关掉(PHANTOM、M+48V)相对应开关。当使用有幻象供电的麦克风时，就按下(PHANTOM+48V)幻象电源开关。

2、信号平衡和非平衡1/4JACK输入，可使CD，电子琴，其他乐器等低电平信号输入。

3、信号1/4JACK输出返回接口。使用1/4双声道插嘴，左边信号为输出，右边信号输入。用于各分路信号输出处理后再返回，如输出至压缩器，均衡器，移频器等。

4、增益控制。根据各路输入的信号强弱，控制各分路的信号增益大小，使每路输的信号增益均衡。

5、分路均衡用于调整分路的音质。根据输入信号的音质进行对HIGH(高音)，MID(中音)，LOW(低音)调整，以达到你所求的音响最佳效果。

6、分路信号输出调节。

7、混响调节。分路分配之机内总混响信号。

8、平衡调节分路分配至总线左右声道信号大小。

9、分路音频信号峰值指示灯。

10、分路主声道切入总线之哑音开关。

11、分路SUB声道切入总线之哑音开关。

12、监听按钮。

13、分路音频大小总调节。

14、立体声左右声道音频输入口。

15、立体声分路音频衰减提升10dB。

16、立体声分路音频高低音调节。分路均衡用于调整分路的音质。根据输入信号的音质进行对HIGH(高音)，LOW(低音)调整，以达到你所求的音响最佳效果。

17、AUX1, AUX2信号输出总音调。

18、AUX1, AUX2信号切入监听按钮。

19、48V幻象电源分配按钮。

MX12-882U: 1-4表示控制第一，二，三，四路幻象供电切换按钮。5-8表示控制第五，六，七，八路幻象供电切换按钮。

MX16-122: 1-6表示控制第一，二，三，四，五，六路幻象供电切换按钮。7-12表示控制第七，八，九，十，十一，十二路幻象供电切换按钮。

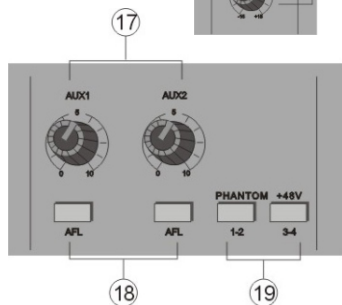
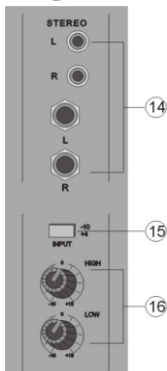
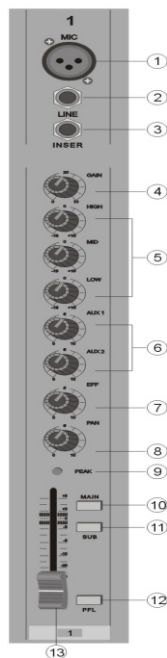

- 20、主声道音频信号输出总调节。
- 21、SUB音频信号输出总调节。
- 22、录音机信号和AUX信号输入音量调节。
- 23、耳机音量调节。
- 24、调节机内混响信号发送至机内混响模块之大小。
- 25、混响延时调节。
- 26、混响重复次数调节。
- 27、混响音频左右声道平衡分配调节。
- 28、混响信号切入主声道哑音开关按钮。
- 29、混响信号切入SUB声道哑音开关按钮。

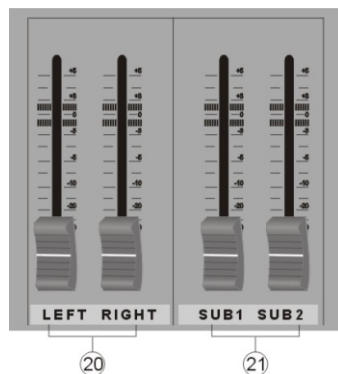

- 30、混响音量总调节。
- 31、混响监听开关按钮。
- 32、主声道信号总混合指示。(当按下机内监听按钮时, 将会切换至显示监听信号)。

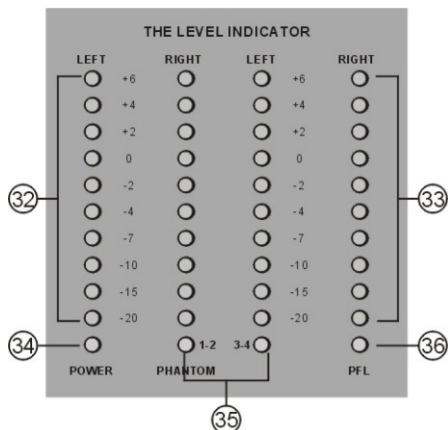

- 33、SUB信号总混合指示。
- 34、电源指示灯。
- 35、48V幻象分配指示灯。
- 36、监听指示灯。
- 37、调音台主通道平衡或者不平衡信号总输出。
- 38、调音台SUB1, SUB2通道不平衡信号总输出。
- 39、AUX1, AUX2单声道信号输出接口。

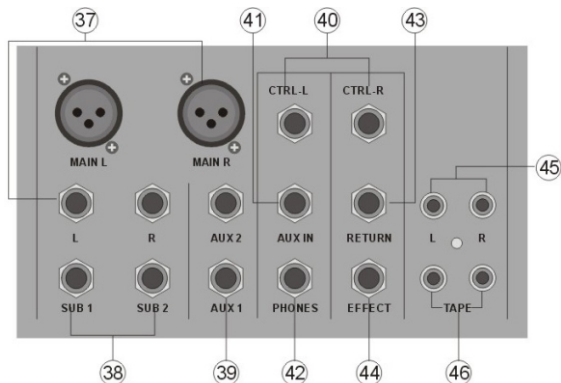

- 40、辅助输出 (受耳机音量调节控制)。
- 41、AUX外接信号返回输入接口。(双声道输入插座)。
- 42、耳机输出接口。(双声道输入插座)。
- 43、机内混响信号外接输出接口。
- 44、机内混响信号, 外接返回输入接口。
- 45、录音信号输出接口。
- 46、RCA输入接口。(受音量控制)

- 47、调音台电源输入接口。将电源插头插好后，务必将螺丝向顺时针旋紧。以免插头的松动使调音台的工作不正常或者烧坏部件。
- 48、调音台电源开关。调音台不使用时，要关闭电源。



四、设备连接示意图

调音台是需要大量的各种连接线来连接各种各样的设备，请务必分清不平衡或平衡的设备连接到调音台的平衡或不平衡的输入或输出中。单声道或双声道的插孔你要对着连接使用，否则将会影响调音台的使用效果。

(1) 调音台连接

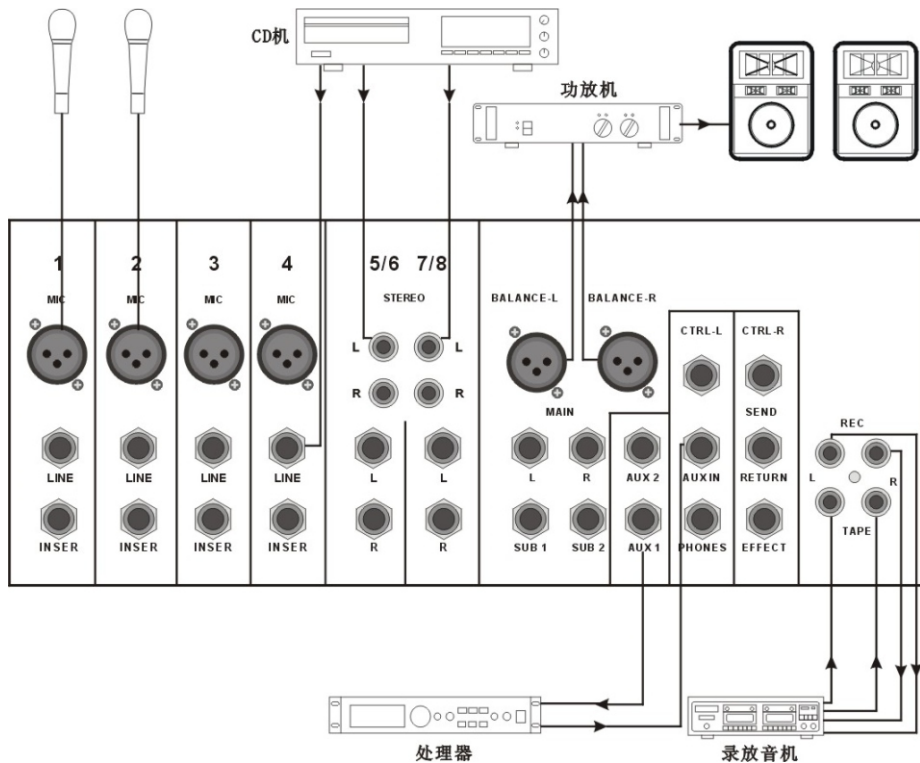

(2) 头戴式耳机连接

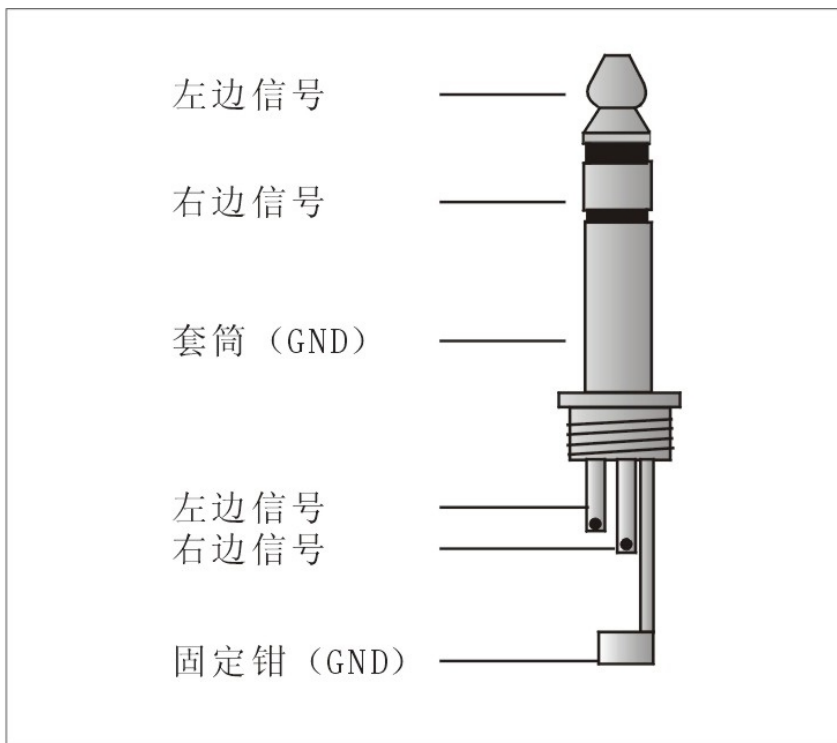

(3) 带平衡的输入连接

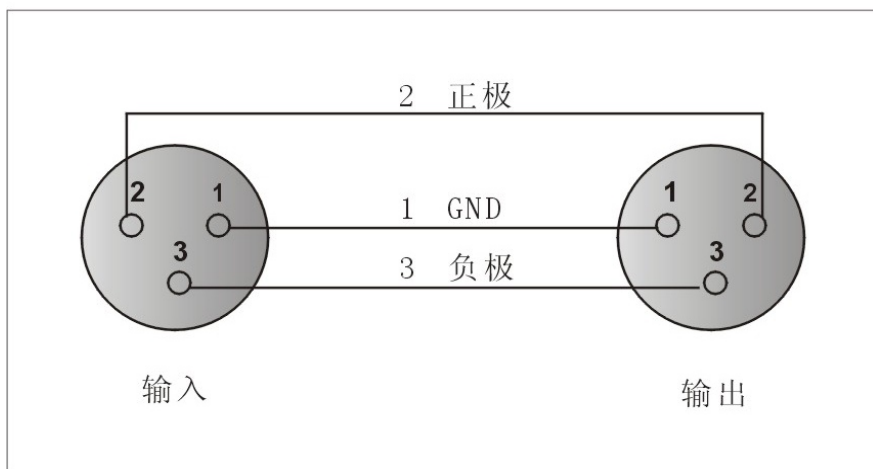

1. Functional Characteristics

- 8CH/12CH/16CH mixer.
- Microphone input with 48V phantom power supply option.
- Mono input is equipped with high quality microphone amplifier.
- 2-way grouped output and 2-way auxiliary output.
- Built-in professional digital reverberation effect device.
- Each channel microphone has a high, medium and low parametric equalizer. Monitor level display.
- Design of external low noise power supply.
- Equipped with recording input and output function.
- With USB recording and playing functions.
- Output mode: main channel and two-channel balance, 6.35 socket. SUB dual channel 6.35 socket.

2. Technical Parameter

Model		MX 8-422U	MX 12-822U	MX 16-122U
Mic Input	Channel	4-way	8-way	12-way
	Phantom Power Supply	48V		
	Frequency Response	20Hz~20KHz(+1dB,-3dB)		
	SNR	71dB		
	THD+N	≤0.05%(1KHz, 0.775V)		
	Maximum input level	19dBm(1KHz, THD=0.5%)		
Mono Input	Channel	4-way	8-way	12-way
	Frequency Response	20Hz~20KHz(+1dB,-3dB)		
	THD+N	≤0.05%(1KHz, 0.775V)		
	Maximum input level	19dBm(1KHz, THD=0.5%)		
Stereo Input	Channel	2-way		
	Frequency Response	20Hz~20KHz(+1dB,-3dB)		
	THD+N	≤0.05%(1KHz, 0.775V)		
	Maximum input level	19dBm(1KHz, THD=0.5%)		
Input Gain	MONO	-55dB~0dB		
	Stereo	-10dB、0dB		
Residual Noise	-75dB			
EQ	LF	80Hz, ±15dB		
	MF	2.5kHz, ±15dB		
	HF	12kHz, ±15dB		
Power Supply	Power supply voltage	AC220V-240V/50Hz-60Hz		
Physical Characteristics	Dimension(L*W*H)	400*400*45mm	443*400*45mm	560*400*90mm
	Weight	4.41kg	5.57kg	7kg

3. Panel introduction

1. Balance the input port of the microphone. When using a non-phantom powered microphone, be sure to turn off the corresponding switch (PHANTO, M +48V). When using a microphone with phantom power supply, press (PHANTOM+48V) phantom power switch.
 2. Signal balanced and unbalanced 1/4JACK input, which can input low-level signals such as CD, electronic organ and other musical instruments.
 3. Signal 1/4JACK output returns to the interface. Use 1/4 dual channel to interrupt, the left signal is output and the right signal is input. It is used to output and process the signals of each branch before returning, such as output to compressor, equalizer, frequency shifter, etc.
 4. Gain control. According to the signal strength of each input path, the signal gain of each input path is controlled to make the signal gain of each input path balanced.
 5. Shunt equalization is used to adjust the sound quality of the shunt. Adjust HIGH (treble), MID (midrange) and LOW (bass) according to the sound quality of the input signal to achieve the best sound effect you want.
 6. Shunt signal output adjustment.
 7. Reverberation adjustment. In-machine total reverberation signal with shunt distribution.
 8. Balance and adjust the signal size of the left and right channels distributed to the bus.
 9. Shunt audio signal peak indicator.
 10. Mute switch for shunting the main channel into the bus.
 11. Mute switch for shunting sub-channels into the bus.
 12. Monitor button.
 13. Total adjustment of shunt audio size.
 14. Stereo audio input ports for left and right channels.
 15. Stereo shunt audio attenuation is improved by 10dB.
 16. stereo shunt audio high and low adjustment. Shunt equalization is used to adjust the sound quality of shunt. Adjust HIGH (treble) and LOW (bass) according to the sound quality of the input signal to achieve the best sound effect you want.
 17. AUX1, AUX2 signal output total tone.
 18. AUX1, AUX2 signal cut into the monitor button.
 19. 48V phantom power distribution button.
- MX12-882U: 1-4 indicates the switch button for controlling the first, second, third and fourth phantom power supply. 5-8 means to control the fifth, sixth, seventh and eighth phantom power supply switching buttons.
- MX16-122:1-6 represents the switch button for controlling the first, second, third, fourth, fifth and sixth phantom power supply. 7-12 indicates the switch button for controlling the seventh, eighth, ninth, tenth, eleventh and twelfth phantom power supply.

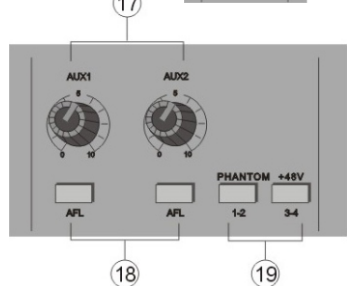
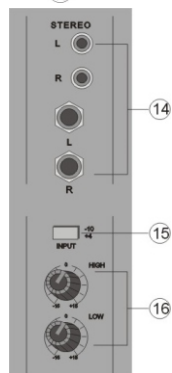
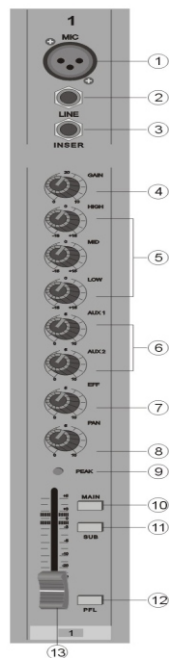

- 20. the main channel audio signal output total adjustment.
- 21. Total adjustment of SUB audio signal output.
- 22. Recorder signal and AUX signal input volume adjustment.
- 23. Headphone volume adjustment.
- 24. Adjust the size of the internal reverberation signal sent to the internal reverberation module.
- 25. Reverberation delay adjustment.
- 26. Reverberation repetition frequency adjustment.
- 27. Reverberation audio left and right channel balance distribution adjustment.
- 28. Reverberation signal cut into the main channel mute switch button.

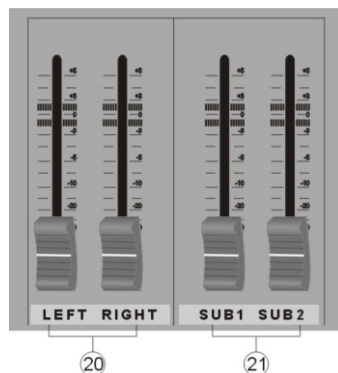

- 29. Reverberation signal cuts into sub-channel mute switeverberation volume total adjustment.
- 31. Reverberation monitor switch button.
- 32. Indication of total mixing of main channel signals (when the monitor button in the machine is pressed, the monitor signal will be switched to display).
- 33. Total mixed indication of SUB signal.
- 34. Power indicator light.
- 35. 48V phantom distribution indicator light.
- 36. Monitor indicator light.
- 37. Total output of balanced or unbalanced signals in the main channel of the mixer.
- 38. Total output of unbalanced signals in sub-1 and SUB1, SUB2 channels of the mixer.

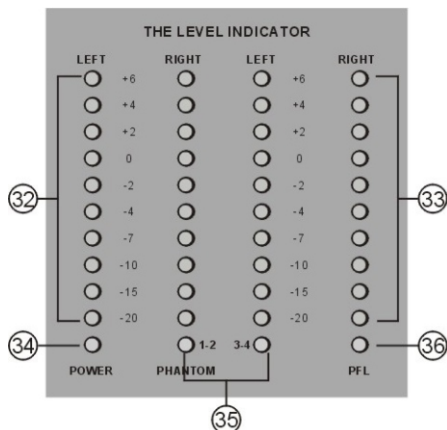

- 39. Aux 1 and Aux 2 mono signal output interfaces.
- 40. Auxiliary output (controlled by earphone volume adjustment).
- 41. AUX external signal returns to the input interface. (Two-channel input socket).
- 42. Headphone output interface. (Two-channel input socket).
- 43. Internal reverberation signal external output interface.
- 44. The internal reverberation signal is externally connected to the input interface.
- 45. Recording signal output interface.
- 46. RCA input interface. (controlled by volume)

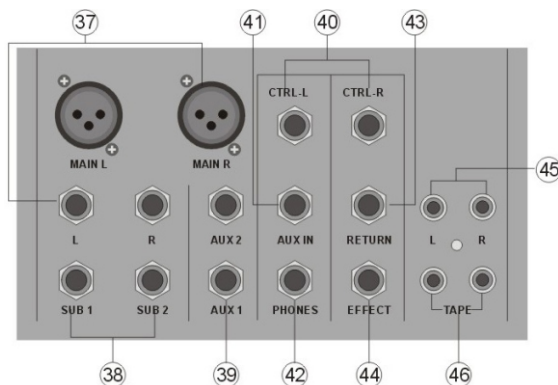

- 47. Mixer power input interface. After inserting the power plug, be sure to tighten the screw clockwise. In order to prevent the loose plug from making the mixer work abnormally or burning out parts.
- 48. Mixer power switch. Turn off the power when the mixer is not in use.



4. Schematic diagram of equipment connection

(1) Mixer connection

The mixer needs a large number of various connecting wires to connect various devices. Please be sure to distinguish between unbalanced or balanced devices connected to the balanced or unbalanced input or output of the mixer. You should use the mono or dual-channel jack facing the connection, otherwise it will affect the use effect of the mixer.

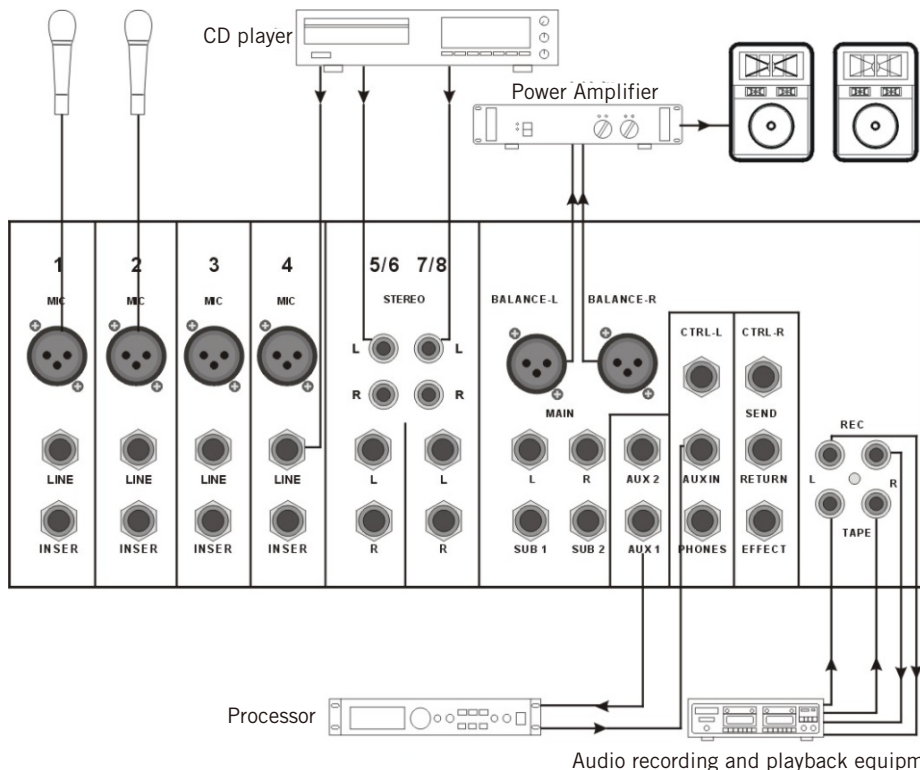

(2) Headset connection

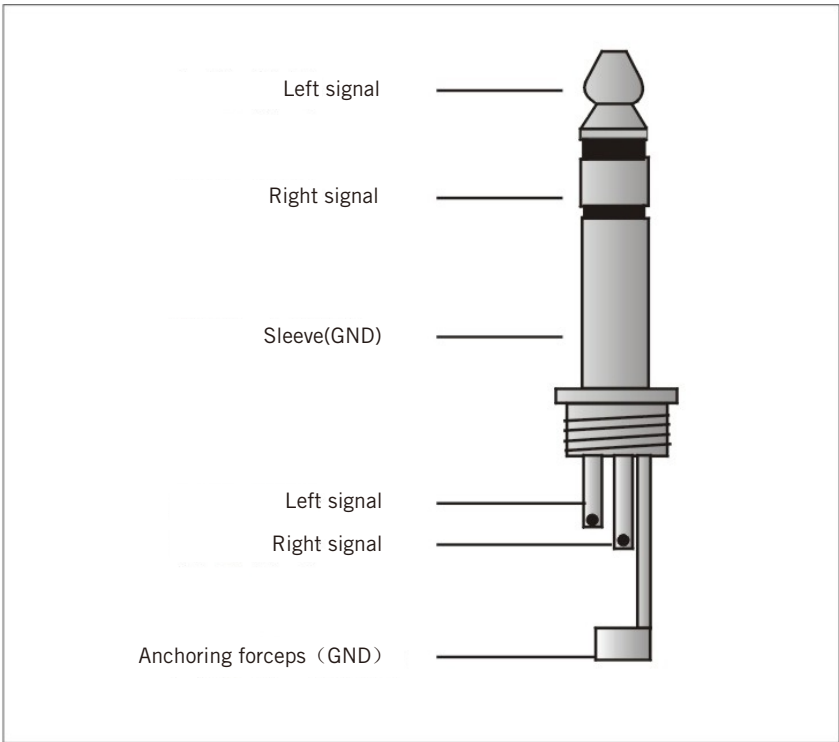

(3) Input connection with balance

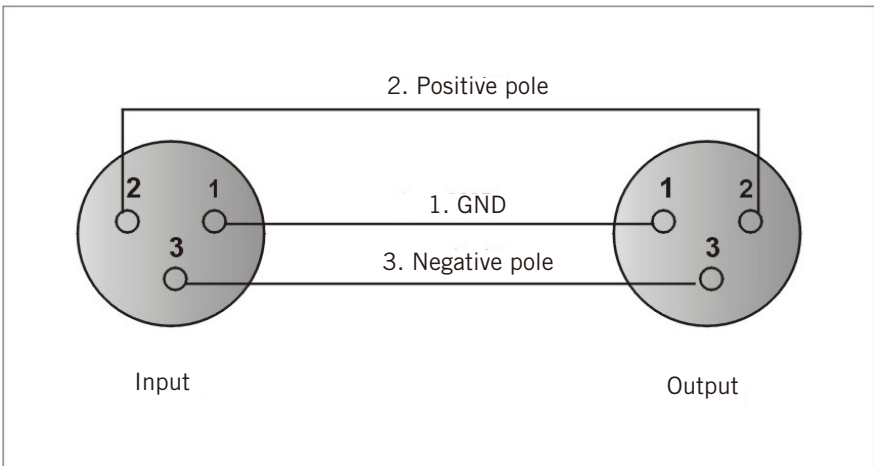

(4) Different kinds of joints

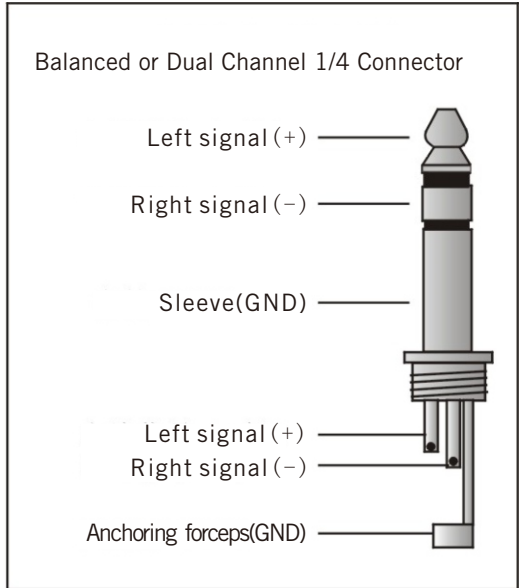
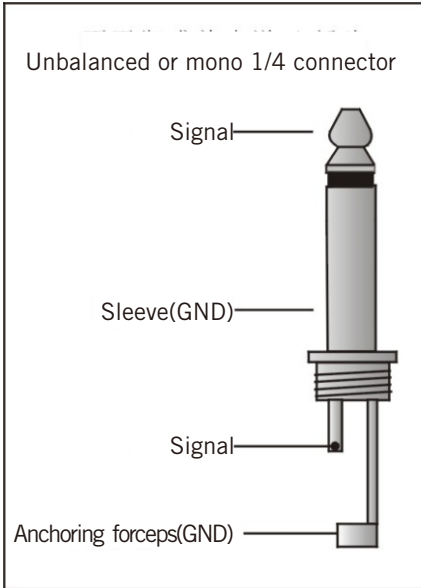

Remarks: Balanced joints and unbalanced joints,+and-cannot be bonded together.

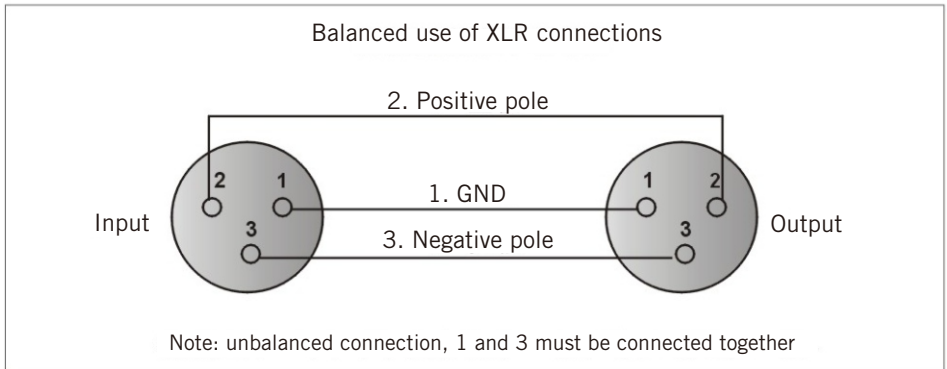



Manufactured to German Standards.
Specifications are subject to change without notice.
© KLOTZ Systems