

INSTALLED SOUND PROFESSIONAL PRODUCT

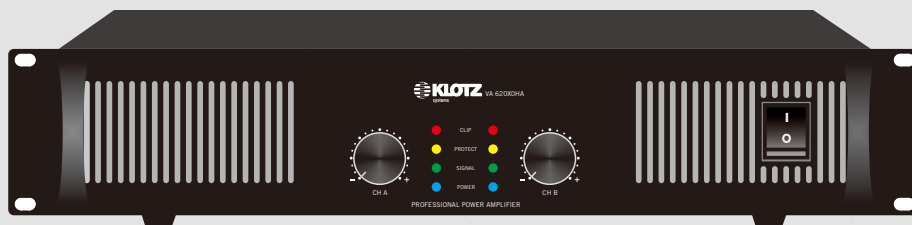

OPERATION MANUAL

VA 62020HA
VA 62040HA
VA 62080HA
POWER AMPLIFIER



Please follow the instructions in this manual to obtain the optimum results from this unit.
We also recommend that you keep this manual handy for future reference.

1. Safety Precautions	4
2. Features	5
3. Specifications	5
4. Introductions	6
5. Operations	7
6. Block Diagram	9
7. Dimensions	10

- Be sure to read the instructions in this section carefully before use.
- Make sure to observe the instructions in this manual as the conventions of safety symbols and messages regarded as very important precautions are included.
- We also recommend you keep this instruction manual handy for future reference.

Safety Symbol and Message Conventions

Safety symbols and messages described below are used in this manual to prevent bodily injury and property damage which could result from mishandling. Before operating your product, read this manual first and understand the safety symbols and messages so you are thoroughly aware of the potential safety.



This symbol is used to alert the operator to follow important operating procedures and precautions detailed in documentation.



This symbol is used to warn operators that dangerous voltages are present within the equipment may cause a risk of electric shock.



WARNING

- Please prevent the equipment dripping by water, do not put the liquid articles such as vase on the equipment.
- The power switch of the equipments is monopole; please pullout the plug if the will not be used for a long time. The switch has already been turn on when the power indicator lamp is on, and the switch has already been turn off when the power indicator lamp is off.
- This machine has no maintain part, for preventing electric shock from being dangerous, do not turn on the machine cover without permission. If need to maintain, please contact sale agent.
- The appearance of the products is subject to material object; we remain the right to modify any issue without notice in advance.



CAUTION

1. Speaker protection

All loudspeakers have electrical, thermal and physical limits which must be observed to prevent damage for failure. Cone or compression drivers can be damaged (sometimes to the point of failure) from excessive power; low frequencies applied the high frequency drivers, severely clipped waveforms, and subsonic signals.

Mid and high-frequency trans-dupers-compression driver in particular are highly susceptible to damage from overpowering, clipped waveforms, or frequencies below their rated pass band. When using an electronic crossover, make absolutely certain that the low and mid bands are connected to the correct amplifiers and driver and note accidentally connected to those for a higher or lower frequency band.

2. Maintenance

Amplifier required no routine maintenance other than occasional cleaning or replacement of the fan intake filters on the rear of the amplifier (This operation does not require any tools). Filters must be kept clear and clean to ensure proper ventilation through the unit. If the amplifier is used in an external dusty or smoky environment, the filter should be cleaned or changed frequently and the unit should be periodically blown free: (using compressed air) of any foreign matter that may penetrated through the filter.

Users will not need to make any internal adjustments to the amplifier during its lifetime. There are no user serviceable parts or adjustments that require opening the power amplifier. Cover removal exposes the risk of shock, so refer all servicing to qualified service technicians authorized by audio.

3. User responsibility

Amplifier is very powerful and can be potentially dangerous to loudspeakers and operators alike. It is your responsibility to read the section titled "precautions" and make sure that the amplifier is installed, wired, and operated properly as instructed in this manual. Many loudspeakers can be easily damaged or destroyed by overpowering, especially with the high power available from a bridged amplifier. Read the section on speaker protection and always be aware of the speaker's continuous and peak power equability. Our Audio is not responsible for damage to loud speakers for any reason.

4. Service and repair

In the unlikely event that your amplifier develops a problem, it must return to an authorized distributor, service center or shipped directly to our factory. To obtain service, contact the nearest audio service center, distributor, dealer, or any of the worldwide audio offices for contact information, reach our company. Customer service directly complexity of the design and the risk of electrical shock, all repairs should be attempted only by qualified technical personnel. If the unit needs to be shipped back to the factory, it must be send in its original carton, if improperly packed, your amplifier may be damaged.

Due to product upgrades, while some of the features and specification in the user manual does not match the actual functions, sorry for any inconvenience and thanks for your kind understanding!

- New design, standard height, suitable for install in 19 inch frame. High-strength structure, installed quickly.
- XLR input interface, support balanced and unbalanced inputs.
- Amplifier is equipped with high efficiency transformer and large-capacity capacitor filter, which ensures low distortion under full load output, low frequency control stronger, clearer sound.
- It suit to many different occasions for language transmission and sound reinforcement.
- Three output modes: Stereo, Mono and Bridged.
- Highly sensitive protection circuit for the output device.
- LED indicators for Power, Protect, Signal and Clip.
- Clipper-limiter and power soft start system prevent the device from damage of impulse current.
- Two output interface: XLR and output terminals, easy to use.
- Optimal cooling efficiency of the dual fan, automatically adjust the fan speed.
- Low noise design.

3. Specifications

Model	VA 62020HA	VA 62040HA	VA 62080HA
8Ω Stereo Output Power	2X200W@8Ω	2X400W@8Ω	2X800W@8Ω
4Ω Stereo Output Power	2X300W@4Ω	2X600W@4Ω	2X1200W@4Ω
2Ω Stereo Output Power	2X400W@2Ω	2X1000W@2Ω	2X1800W@2Ω
8Ω Bridging Output Power	500W@8Ω	1000W@8Ω	2000W@8Ω
4Ω Bridging Output Power	600W@4Ω	1200W@4Ω	2400W@4Ω
Frequency Response	20~20kHz(-0.5dB)		
THD	≤ 0.05% RMS @ 8Ω 1kHz		
Damping Factor	400:1	450:1	550:1
SNR	90dB	95dB	103dB
Input Sensitivity	32dB/1v/1.4v		
Input Impedance	20kΩ Balanced or 10kΩ Unbalanced		
Voltage Gain	32dB		
Input Connector	Balanced XLR		
Output Connector	Terminal and SPEAKON Connector		
Power Supply	220~230 VAC, 50/60Hz		
Dimension (W*D*H)	483x430x88mm		
Weight	12.5kg	14.3kg	17.5kg

VA 62020HA/VA 62040HA/VA 62080HA Front Panel

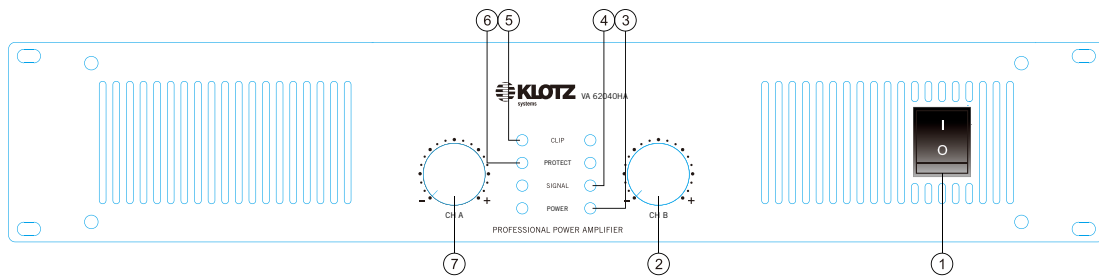

1. Power Switch
2. CH A volume control Knob
3. Power LED(Blue)
4. Signal LED(Green)
5. Clip LED(Red)
6. Protect LED(Yellow)
7. CH B volume control Knob

VA 62020HA/VA 62040HA/VA 62080HA Rear Panel

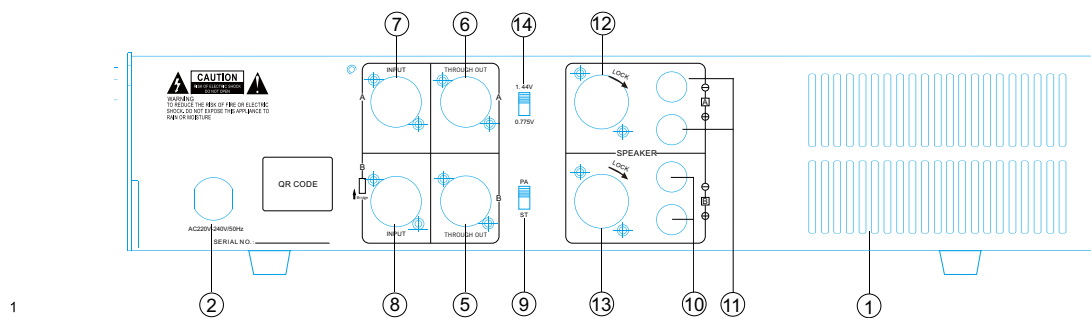

1. Fan inlet ports and Filters
2. Power interface
3. I-PAM card interface(Optional accessories, additional charge.)
5. CH B link output interface
6. CH A link output interface
7. CH A input interface
8. CH B input interface
9. Mode Switch
10. CH B output terminal
11. CH A output terminal
12. CH A XLR output interface
13. CH B XLR output interface
14. Gain adjustment switch

5.1 Preparation

Make sure that the supply voltage is consistent with the voltage marked on the rear panel. Remember to turn off the power switch before plug in the power supply plug or wiring the system. We are not responsible for the damage caused by any mistake of power supply.

Before starting, please turn the volume to the minimum degree of the machine, in order to prevent the input signal is too strong to damage the loudspeaker.

Choose high quality electric outlet and which has enough power capability. Inferior electric outlet is bad for the machine, and could not bring out the best performance of our product.

5.2 Input signal connection

The input signal can be connected to XLR socket. Our recommendation is to use the balanced input method (figure 5-1) that could efficiently reduce the AC noise when the signal cables is too long. You can find the unbalanced input method in figure 5-2.

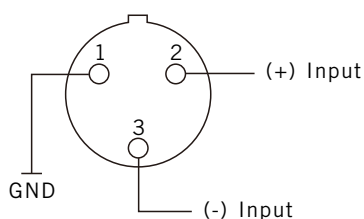

Figure 5-1
Balanced

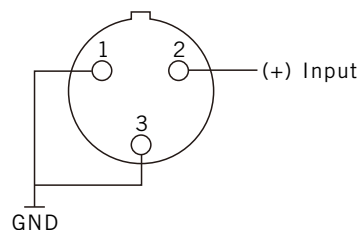

Figure 5-2
Unbalanced

5.3 Output signal connection

Cables with XLR or naked wire can be connected to the XLR socket or the terminal on the rear panel (more details refer to rear panel). The cross sectional area of the cable depends on the impedance of the loudspeaker and the cable length.

The red terminal is positive output port which should be attached to the positive terminal of loudspeaker; the black terminal is ground output port which should be attached to the negative terminal of loudspeaker. (Please refer to 5.6 for the output connection of Bridged Mono mode)

5.4 Connection of the power supply

Different types of machine have different requirements on the electric outlet power capacity. Low power capacity of the electric outlet cannot bring out the best performance of the machine.

There has no voltage convertor in the machine, so please pay attention to the working voltage when you buying. There has the risk of electric shock when open the cover, so all repairs and maintain should be attempted only by qualified technical personnel.

5.5 Stereo mode and Parallel mode

In stereo mode, two signal input and two knob separately control the volume of two channels, CH A input signal be amplified by CH A and which output to CH A output interface, CH B input signal be amplified by CH B and which output to CH B output interface.

When set to "PA" mode, the signal of "THROUGH" interface is line signal, and the signal can not control by the knob on front panel.

5.6 Bridged Mono mode

This amplifier can set to Bridged Mono mode.

Bridged Mono mode straps both amplifier channels together to make a very powerful, single channel monaural amplifier. At this time, signal comes from the CH A input interface, and be amplified by CH A and CH B. The signal is controlled by CH A knob.

The "+" of loudspeaker connected to the positive pole of the amplifier, and the "-" of loudspeaker connected to the negative pole of the amplifier.



Do not connect the positive output to the ground or to another positive output!

5.7 Notice for Bridged Mono mode

In the Bridged Mono mode, do not connect any terminals of the loudspeaker to ground, because two terminals of the amplifier are positive pole that should be insulated to the ground. Meanwhile, do not turn the operation mode switch when the machine is powered on.

5.8 Gain Control

Two control knobs on the front panel are used to adjust the gain voltage of two channels in Stereo mode. When the input signal voltage is 1.1V and two knobs are rotated clockwise to "max" scale, the output of the power amplifier is rated power.

In Bridged Mono mode, only use the CH A knob to adjust the volume, the CH B knob is invalid.

5.9 Switch of operating mode

The switch of operating mode on the rear panel can be selected between Stereo mode or Bridged Mono mode. Please refer to 5.5 and 5.6 for more details.

5.10 LEDs Indicator

LEDs Indicator on the front panel are instructions of operation status.

(1) Power LED (POWER)

Blue Power LED will light up when the power switch is turned on.

(2) Signal LED (SIGNAL)

Green signal LED will light up when the signal input to the channel.

(3) Protect LED (PROTECT)

Yellow LED will light up in the following situation:

A: 3 seconds of delay circuit when starting the machine.

B: If DC output occurs in current channel.

C: If temperature is too high in current channel.

(4) Clip LED (CLIP)

The red LED is shining indicates that the machine is working well and in critical clipping status. If the LED is bright, it means that the machine is working in clipping status, should reduce the gain to prevent damage the loudspeaker from the severe clipping output signal.

5.11 Protect function

This series amplifiers are equipped with different protective circuits, including output short circuit, DC and temperature protection, protection against the impulse current during startup & shutdown. All of these protections ensure the reliability of the power amplifier.

Any channel malfunctions, their channel's LED will light up until the troubleshooting.

(1) Temperature protection

Cooling fan of the machine ensures proper ventilation. Once the channel radiator reaches 85°C, the electrical load will be automatically cut out, protect LED lights up and will put out until the temperature under to 75°C.

(2) DC protection

Any DC output occurs, output relay of this channel would be disconnected immediately, and the DC protection LED will be turned on accordingly.

(3) Startup & shutdown protection

The output relay will be connected to loudspeaker after 3 to 5 seconds of delay for the startup, while the output relay will disconnect all the outputs instantly when the machine is shutdown. Thus, no impulse current outputs will be generated when switching machine.

(4) Short circuit protection

The protective circuit of short circuit within the machine can detect immediately and response to the failure, clipping indicator will light up in this case, and the channel goes into the protected status. After the exclusion of short circuit, the machine will go back to the working state and clip indicator puts out.



Do not use signals below the nominal frequency to drive the loudspeaker!

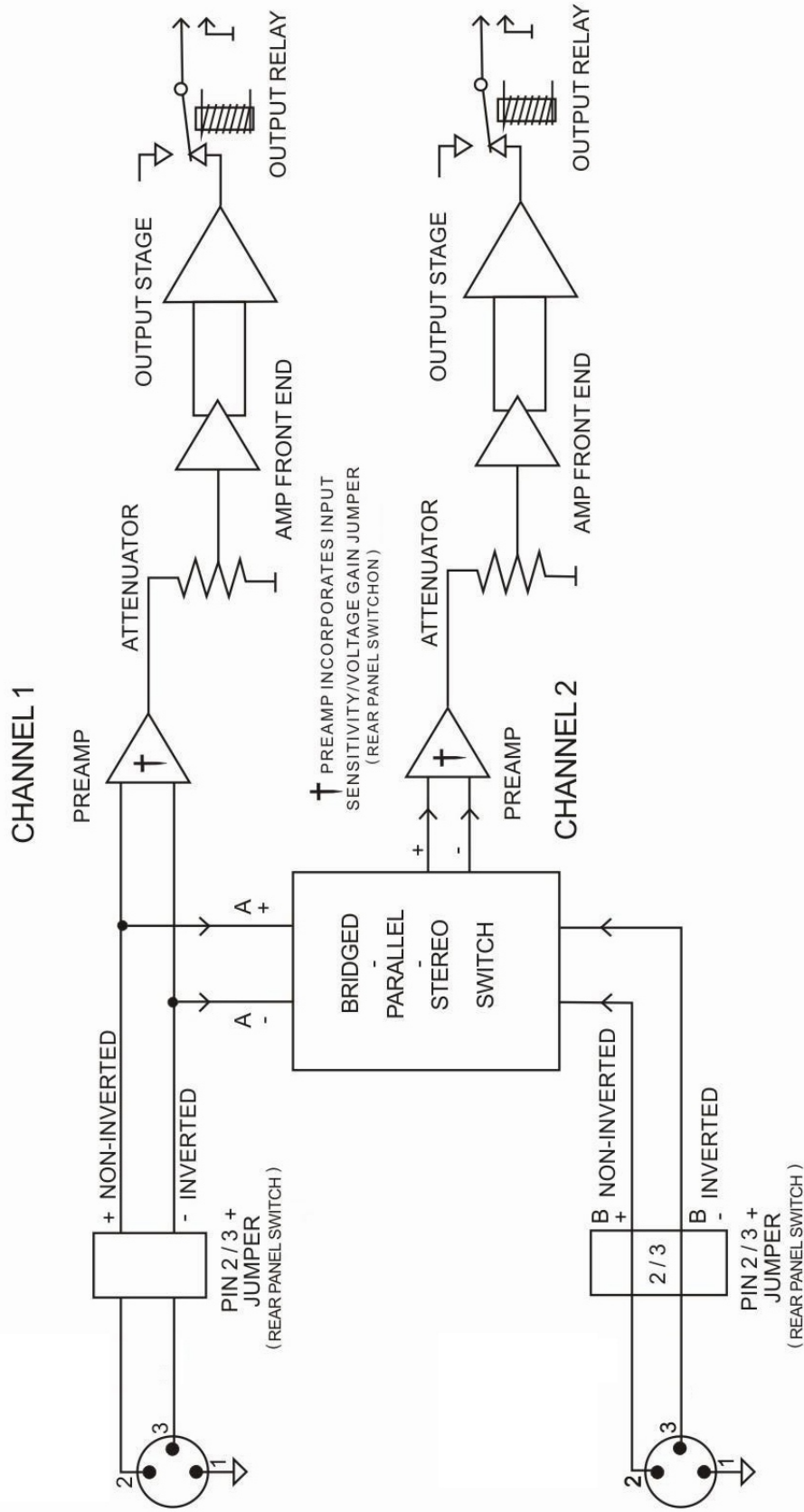

Suit for VA 62020HA/VA 62040HA/VA 62080HA

VA 62020HA/VA 62040HA/VA 62080HA Front Panel

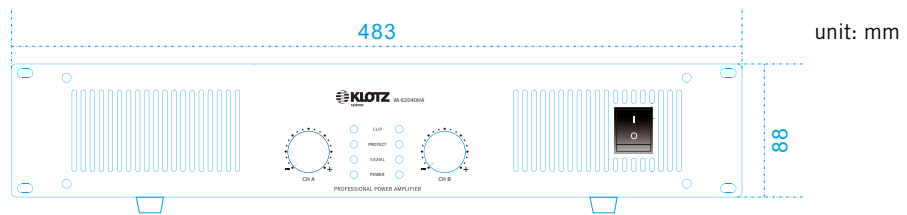

VA 62020HA/VA 62040HA/VA 62080HA Rear Panel

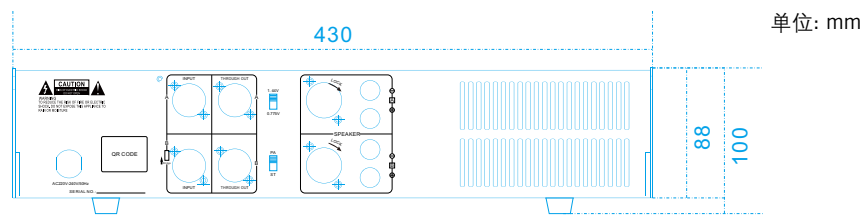

VA 62020HA/VA 62040HA/VA 62080HA Side Panel

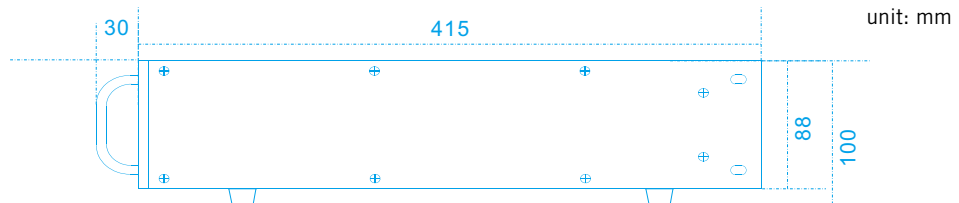

Keep the unit's all sides over 10 cm away from objects that may obstruct air flow to prevent the unit's internal temperature rise.

Unit: mm

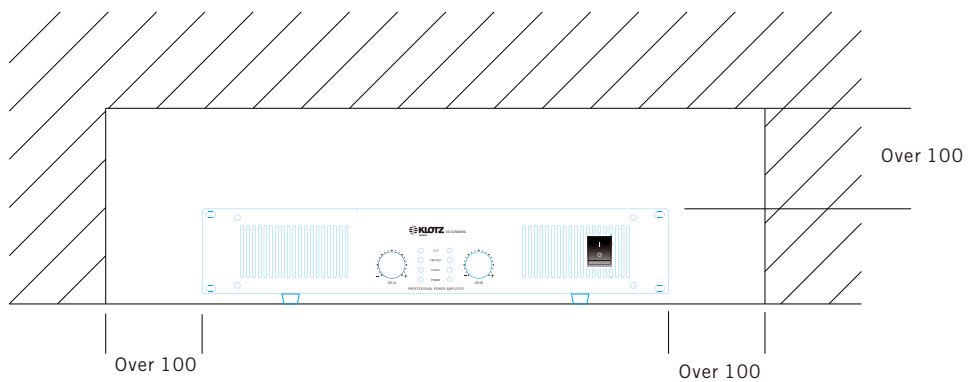

1. 安全须知.....	12
2. 产品特性.....	13
3. 规格参数.....	13
4. 产品说明.....	14
5. 操作说明.....	15
6. 方框图.....	17
7. 尺寸图.....	18

- 使用之前请仔细阅读此手册。
- 本手册作为安全标志与消息提示的规定，包含十分重要的安全须知内容，需认真浏览。
- 建议您将本手册保留下来以便随时查阅。

安全标志及消息提示

下文所描述的安全标志及消息提示，是用来防止操作不当造成的设备损坏和财产损失。在使用产品之前，首先请浏览并理解安全标志及消息提示的含义，然后再开始安全使用产品。



这个标志是用来提醒用户，要根据文档中详细的提示和说明进行操作。



这个标志是用来警告用户，设备在高电压下工作，有发生触电的危险。



警告

- 请防止水滴溅入设备，不要把水容器如花瓶等放置在设备上。
- 设备的电源开关是单极的，如果长时间不使用设备，请断开电源插头。打开电源开关时，电源指示灯将会亮起，反之电源开关关闭时，电源指示灯则会熄灭。
- 为了防止发生触电危险，在未获得许可的情况下不要打开设备。如果需要维修，请联系专业售后部门。
- 产品外观请以实物为准，相关改进恕不另行通知。



提醒

1. 扬声器保护

所有扬声器都有电学、热学及物理方面的限制，所以必须遵守相关规定，以防设备损坏。功率过高可能对锥形和压缩驱动器造成损坏（有时达到故障点）；高频驱动器用于低频，会造成严重的削波和超低音信号。

特别是中高频压缩驱动器非常容易受过载、削波或者频率低于它们额定通过频带的影响而损坏。当使用电子分频器时，必须确保低频和中频频带连接到正确的放大器和驱动器上，并注意连接它们到更高或更低频带的意外情况。

2. 维护

除了偶尔对功放后面板风扇通风口过滤器进行清理或更换外（不需要任何工具），功放的其他部分不需要日常维护。通风口过滤器必须保持干净整洁，以保证功放能够正常散热。如果功放放在灰尘烟雾特别多的环境下长期使用，对通风口就需要定期清洁或更换：使用压缩空气或者其他能穿过过滤器的方式清洁。

在设备的整个使用期间都不需要对功放内部进行任何调整。禁止打开功放。拆卸可能会有触电危险，因此建议有需要时请咨询专业技术人员。

3. 用户责任

功放的功能非常强大，可能对扬声器和操作员造成潜在危险。所以一定要认真阅读“安全须知”，以保证功放在安装、接线和运行都按照手册执行。许多扬声器非常容易受到过载特别是来自大功率的桥接功放的损坏。请仔细阅读扬声器保护部分，并一直保持扬声器的连续功率和峰值功率的稳定。我们对扬声器的损坏不负任何责任。

4. 服务与维修

当功放出现问题，必须向授权分销商、授权服务中心或直接向我们的工厂寻求帮助。联系最近的音频服务中心、分销商、经销商或是世界各地的音频办公室，都可以得到我公司的联系方式。由于产品内部设计的复杂性以及会有触电风险，任何维修动作都必须由专业维修技术人员进行。如有需要将产品寄回原厂，则必须使用原始包装箱装好，如果包装不当，运输途中功放也可能被损坏。

由于产品升级，手册中的部分产品特性与参数也会相应修改，因此手册描述可能会与实际功能有出入。给您带来的不便深表歉意，谢谢理解！

- 全新外观设计，标准机箱高度，适合安装在19"机柜安装放置。高强度结构机箱，装配快捷。
- XLR输入接口，支持平衡和非平衡输入。
- 具备有高效率大型变压器，大容量电容的滤波电源。保证功放满负荷输出时极低失真，低频控制力更强，声音更清晰。
- 适合多种不同场合的语言传输和扩声。
- 立体声、单声道、桥接三种输出方式。
- 高灵敏度安全保护电路。令扬声器等输出设备更安全。
- 电源、保护、信号、削波LED工作状态指示。
- 削波限幅、电源软启动系统。用继电器延时的电路实现开机的软启动特性，从而保护了扬声器免受开机时的电流冲击。
- 具有XLR和接线柱两种输出方式，使用灵活方便。
- 高效率双风扇冷却，自动调节风扇转速。
- 低噪音设计。

3. 规格参数

型号	VA 62020HA	VA 62040HA	VA 62080HA
8Ω立体声输出功率	2X200W@8Ω	2X400W@8Ω	2X800W@8Ω
4Ω立体声输出功率	2X300W@4Ω	2X600W@4Ω	2X1200W@4Ω
2Ω立体声输出功率	2X400W@2Ω	2X1000W@2Ω	2X1800W@2Ω
8Ω桥接输出功率	500W@8Ω	1000W@8Ω	2000W@8Ω
4Ω桥接输出功率	600W@4Ω	1200W@4Ω	2400W@4Ω
频率响应	20~20kHz(-0.5dB)		
总谐波失真	≤0.05% RMS @ 8Ω 1kHz		
阻尼系数	400:1	450:1	550:1
信噪比	90dB	95dB	103dB
输入灵敏度	32dB/1v/1.4v		
输入阻抗	20kΩ平衡或或10kΩ非平衡		
电压增益	32dB		
输入连接器	平衡输入XLR		
输出连接器	接线柱和SPEAKON连接器		
供电电压	220~230 VAC, 50/60Hz		
尺寸(W*D*H)	483x430x88mm		
重量	12.5kg	14.3kg	17.5kg

VA 62020HA/VA 62040HA/VA 62080HA 前面板

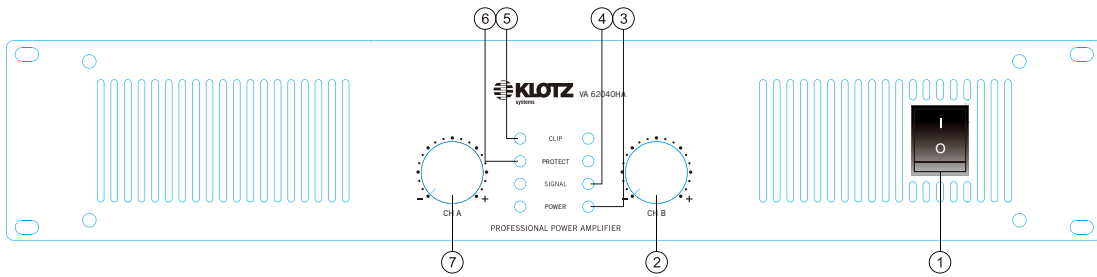

1. 电源开关
2. CH A(1)音量调节旋钮
3. 电源指示灯 (蓝色)
4. 信号指示灯 (绿色)
5. 峰值指示灯 (红色)
6. 保护指示灯 (黄色)
7. CH B(2)音量调节旋钮

VA 62020HA/VA 62040HA/VA 62080HA 后面板

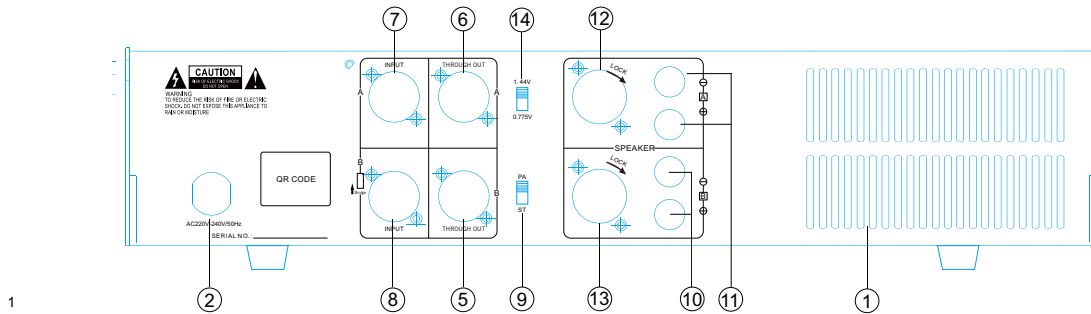

1. 风扇进风口及过滤器
2. 电源接口
3. I-PAM板卡接口 (可选配件, 需额外付费)
4. 保险丝
5. CH B并联输出口
6. CH A并联输出口
7. CH A输入口
8. CH B输入口
9. 功放工作模式切换
10. CH B接线柱输出
11. CH A接线柱输出
12. CH A卡依头输出
13. CH B卡依头输出
14. 增益调节开关

5.1 开机前的准备工作

要确保供电电源电压与机器背后所示电压相同，本公司不负责因电源误接而造成的损坏，系统连接期间及电源插头插上之前一定要关闭电源开关。

开机前，最好将音量旋钮调到最小，以防输入信号过大损坏扬声器。

请选用优质电源插座并确保足够的功率容量，劣质的电源插座会影响机器正常使用，而且不能发挥出机器的最好性能。

5.2 输入信号线接法

输入信号可连接到卡侬插座上，平衡输入接法见图5-1，不平衡输入接法见图5-2，建议优先采用平衡输入接法，尤其当信号线较长时，可有效地减少交流噪声。



图5-1
平衡输入接法



图5-2
非平衡输入接法

5.3 输出信号的接线方法

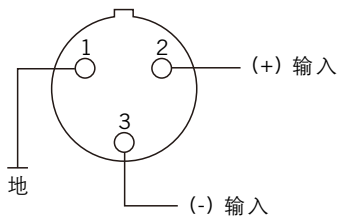
音箱线可选用卡侬头或裸露线头连接到机器背后的插座或接线柱上（详见机器后板图），应根据扬声器阻抗功率及音箱线的长短来确定音箱线的截面积。

红色接线柱是“正”输出端，接扬声器“正”极，黑色接线柱是“地”输出端，接扬声器的“负”极（桥接单声道输出时的接线方法可参照“5.6”）。

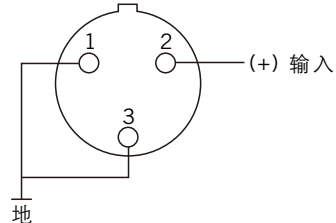
5.4 供电电源的连接

不同型号的机器对供电电源插座的容量有不同的要求，低于容量时机器不能发挥出最佳性能。

机器内部不带电压切换装置，认购时请注意机器的使用电压，打开机盖有触电的危险，所有维修保养服务必须由合格的技术人员进行操作。

5.5 立体声双声道工作方式、并联工作方式

选用立体声双声道工作方式时，将工作方式选择开关设置在“STEREO”位置，两个信号输入，两个音量控制器分别控制两个声道的音量，A声道输入的信号经A声道放大后在A声道输出，B声道输入的信号经B声道放大后在B声道输出。

当设置在“PA”位置时，信号从CH A/CH B输入，从THROUGH口输出，输出信号为线路信号，不受前面板旋钮控制。

5.6 桥接单声道工作方式

根据需要放大器可作桥接单声道工作方式使用。

当工作方式选择开关设置在“BRIDGED”位置时，机器的两个声道可以桥接成一个功率更大的单声道功率放大器，这时候，信号从A声道输入插座输入，通过CH A和CH B放大后输出，仅受CH A的增益控制器调节控制。

扬声器的“+”极接A声道的“正”端，“-”极接B声道的“正”端。



切勿把“正”输出端接地或与另一“正”输出端相连！

5.7 桥接使用注意事项

当机器处于桥接单声道工作方式时，切勿将任一扬声器接线端子接地，因为两个端子都是“正”端，如果使用输出接线板时，所有端子必须对地绝缘。在桥接工作时，不要在开机状态下拨动工作方式选择开关。

5.8 增益控制

机器前面板上有两个增益控制旋钮，双声道工作方式时，两个旋钮分别控制两个声道的电压增益，当输入信号电压为 1.1V，两个增益控制旋钮顺时针转到“最大”刻度时，功率放大器输出为额定功率。

在桥接单声道工作方式状态下，只用A声道增益控制旋钮改变音量的大小，B声道增益控制旋钮无效。

5.9 工作方式选择开关

机器后板上设有工作方式选择开关，此开关可将机器设置为双声道工作方式或桥接单声道工作方式，详细请参阅“5.5”，“5.6”。

5.10 工作状态指示灯

功率放大器面板上装的LED指示灯，是用来显示每声道的工作状态

(1) 电源指示灯 (POWER)

当电源开关合上时，该蓝色电源指示灯点亮；

(2) 信号电平指示灯 (SIGNAL)

该绿色指示灯点亮，表示有信号输入到该声道的信号输入端。

(3) 保护指示灯 (PROTECT)

该黄色指示灯是机器处于保护状态时点亮，具体有以下几点

A: 开机时为保护扬声器而设置的延时电路的工作状态指示（约3秒钟后会自动熄灭）

B: 该声道的输出有直流电压

C: 该声道温度过高

(4) 削波指示灯 (CLIP)

该红色指示灯暗淡地闪亮属正常现象，说明机器工作在临界削波状态，如果该指示灯连续发出亮光，说明机器工作在削波状态，这时需要降低增益，以免严重的削波输出信号损坏扬声器。

5.11 保护功能

此系列功率放大器设计有多种保护电路，以便在各种情况下对本机及扬声器进行保护，包括输出短路保护，直流电压及温度保护，开机、关机时的冲击电流保护，使得此功率放大器非常可靠。

当发生故障使某一声道进入保护状态时，相应的保护指示灯点亮。包括输出端出现直流电压或温度过高，该声道的输出继电器会自动断开扬声器，直到机器降温或排除故障为止。

(1) 温度保护

在正常情况下，机器内的散热风扇将保持机器处于正常的工作状态，如果因为各种原因导致某一声道的散热器温度达到85°C时，该声道将自动断开所接的负载，这时候保护指示灯发亮直到散热器温度下降到75°C时，电路会自动恢复正常工作，保护指示灯会熄灭。

(2) 直流电压保护

如果机器的某一声道的输出端出现直流电压，这一声道的输出继电器会立即断开，保护扬声器免受损坏，这时，保护指示灯会发亮。

(3) 开机/关机保护

开机时输出继电器会延时3-5秒后才吸合接通扬声器，关机时，输出继电器会立刻断开输出，所以开机和关机都不会有冲击电流输出。

(4) 短路保护

输出端短路时，机器内的短路保护电路可立刻检测并动作，削波指示灯点亮，机器的这个声道立刻进入保护状态，排除短路现象后，机器立刻进入工作状态，削波指示灯会熄灭，保护机器在安全范围内工作。



切勿使用低于扬声器标称频率的信号驱动扬声器!

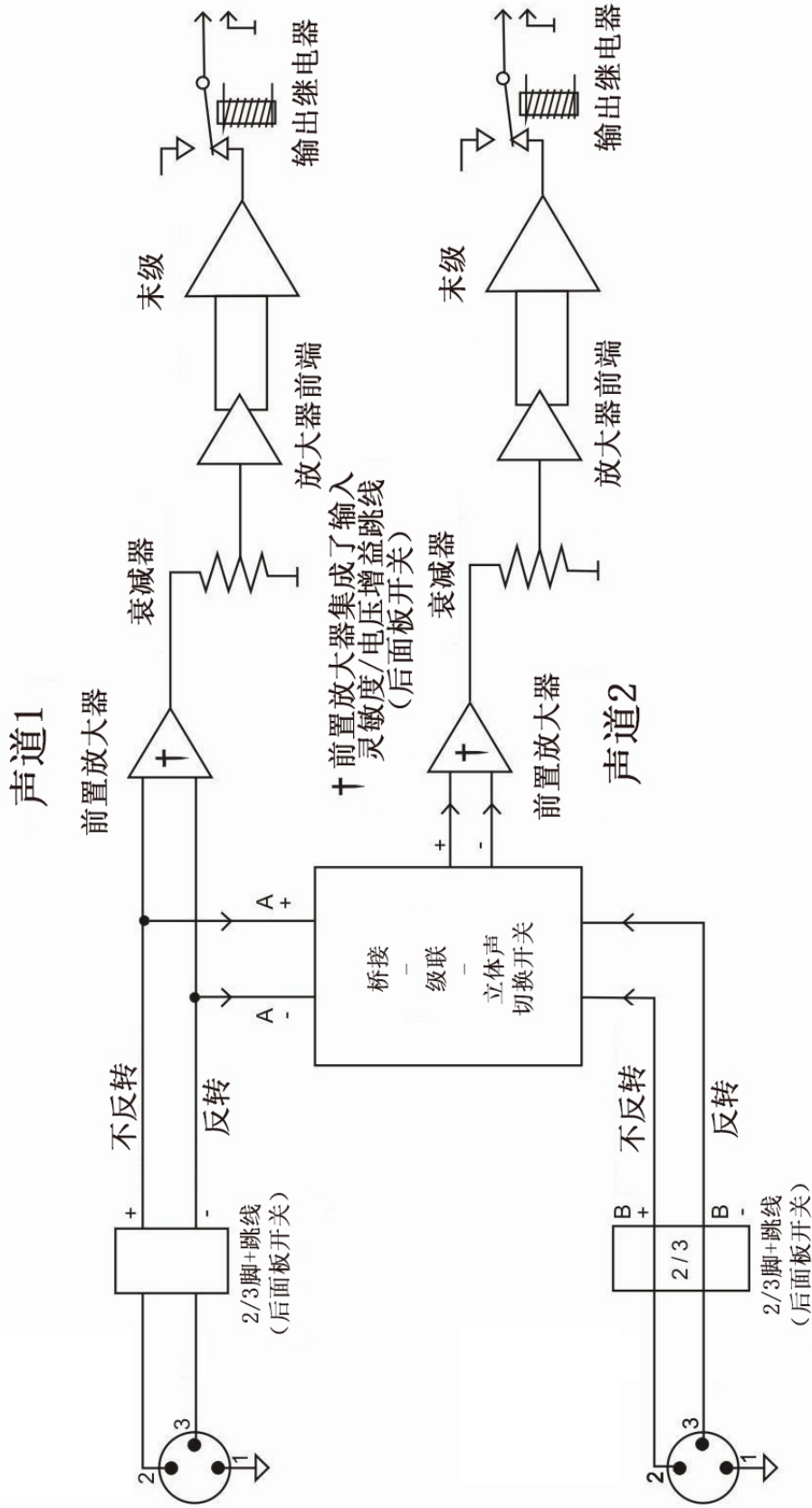

适用于VA 62020HAVA 62040HAVA 62080HA

VA 62020HA/VA 62040HA/VA 62080HA 前面板

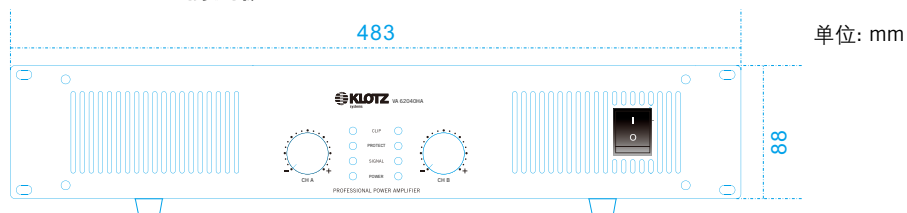

VA 62020HA/VA 62040HA/VA 62080HA 后面板

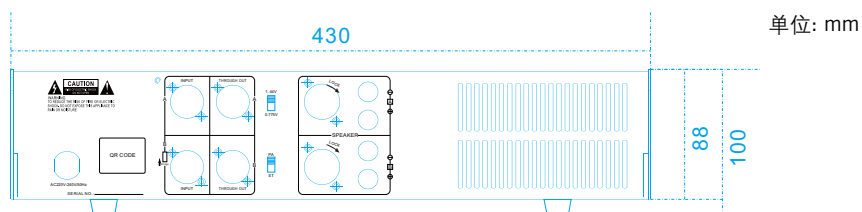

VA 62020HA/VA 62040HA/VA 62080HA 侧面板

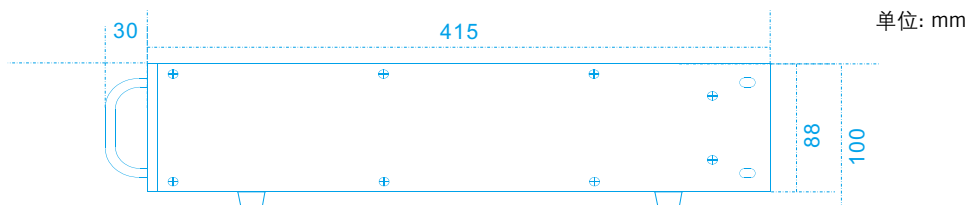

功放工作时，保证功放各个面与物体的距离大于10厘米，否则会阻碍空气流通，以防设备内部温度过高。

单位: mm

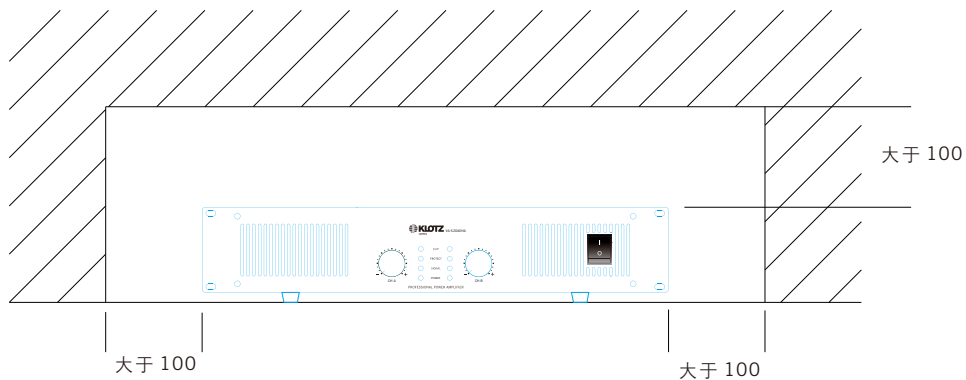

INSTALLED SOUND PROFESSIONAL PRODUCT



**Manufactured to German Standards
Specifications are subject to change without notice**

Version V0.1